

(No Model.)

3 Sheets—Sheet 1.

J. HARTNESS.
ATTACHMENT FOR TURRET LATHES.

No. 587,480.

Patented Aug. 3, 1897.

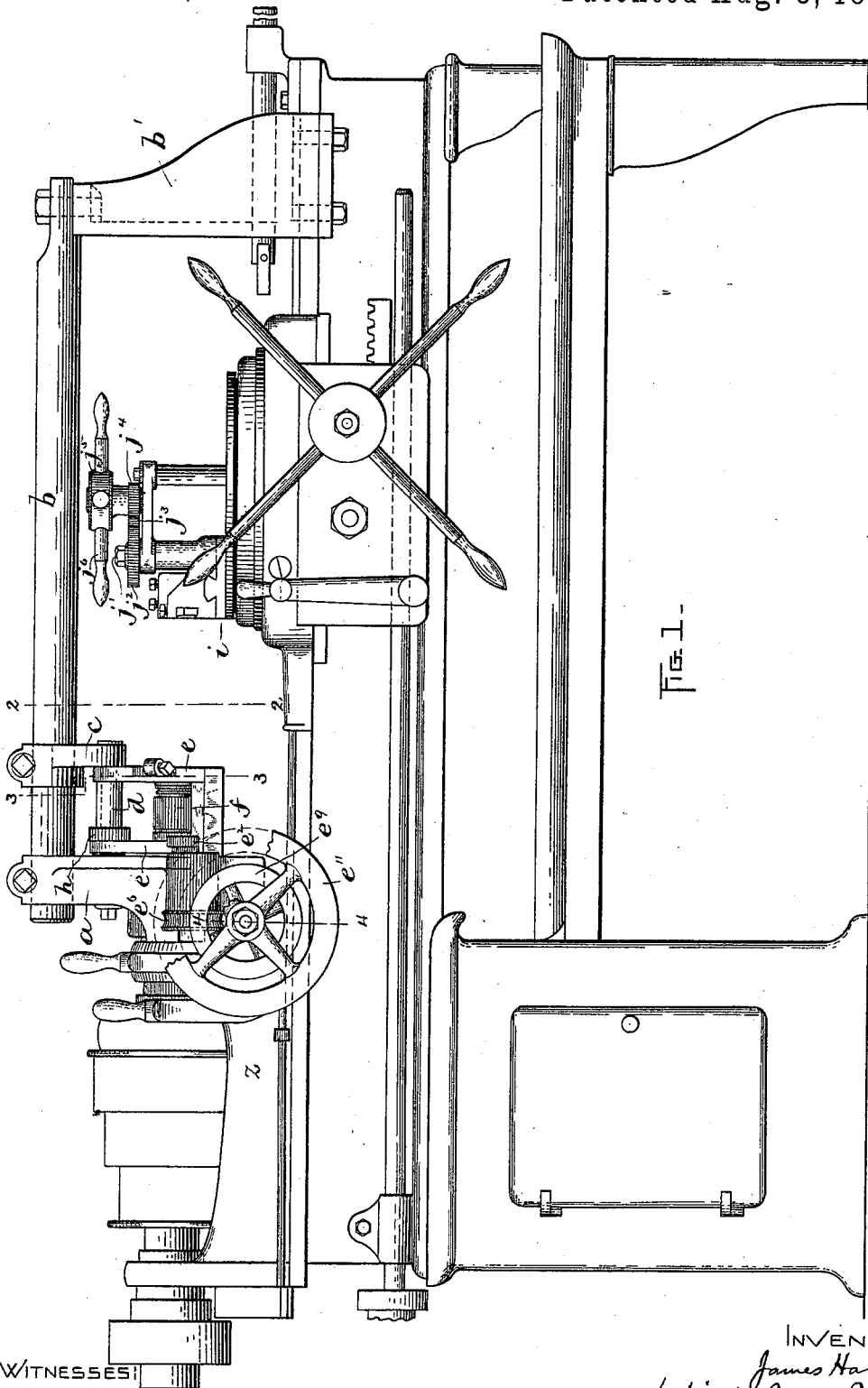

FIG. 1-

WITNESSES:
A. S. Harrison.
P. W. Pizzetti

INVENTOR:
James Hartness
by Knight Brown & Quincy
attys.

(No Model.)

3 Sheets—Sheet 3.

J. HARTNESS.
ATTACHMENT FOR TURRET LATHES.

No. 587,480.

Patented Aug. 3, 1897.

FIG. 6.

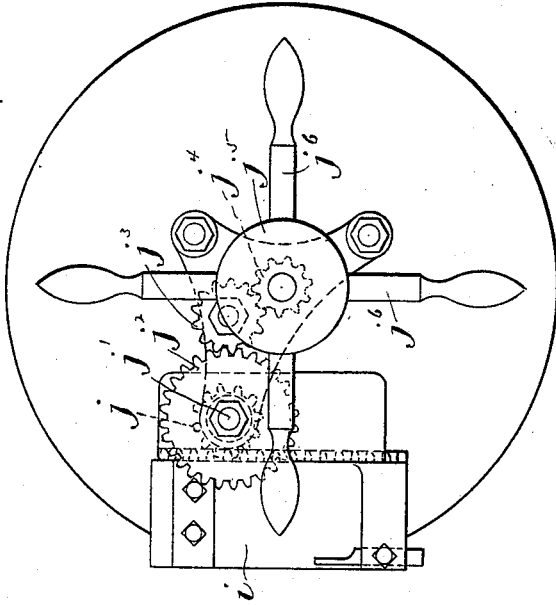
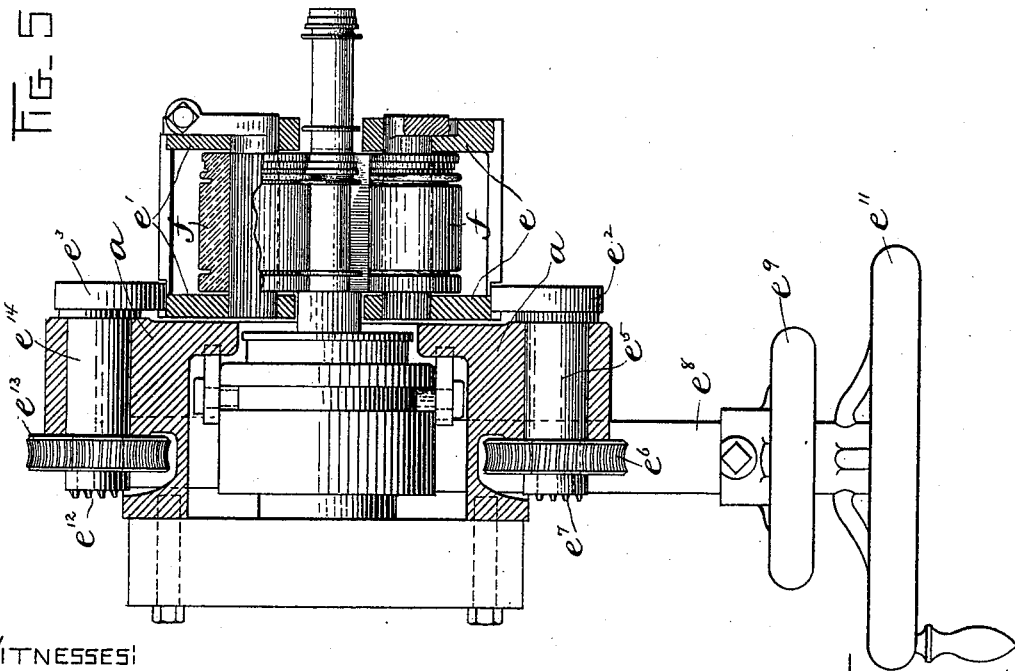

FIG. 5.



WITNESSES:
A. D. Harrison.
P. W. Pizzetti.

INVENTOR:
James Hartness
 by *Wright Brown & Quincy*
attys.

UNITED STATES PATENT OFFICE.

JAMES HARTNESS, OF SPRINGFIELD, VERMONT.

ATTACHMENT FOR TURRET-LATHES.

SPECIFICATION forming part of Letters Patent No. 587,480, dated August 3, 1897.

Application filed June 11, 1896. Serial No. 595,073. (No model.)

To all whom it may concern:

Be it known that I, JAMES HARTNESS, of Springfield, in the county of Windsor and State of Vermont, have invented certain new and useful Improvements in Attachments for Turret-Lathes, of which the following is a specification.

This invention relates to metal-turning lathes, and more particularly to turret-lathes of the type shown in my former patent, No. 457,967, granted August 18, 1891; and the invention contemplates certain attachments to such a lathe whereby one or more broad tools can be brought to bear on the work entirely independent of the turret and its adjuncts, while at the same time perfect control of such broad tools is assured. The invention also has in view to provide improved means for operating the tool-slide carrying the broad tools on the turret, whereby great leverage is obtained and accidents to the operator and to the parts of the machine avoided.

Although, as above stated, the invention has been specially devised for application to a lathe of the type shown in my former patent, No. 457,967, yet it is capable of adaptation to other types of lathes and is not limited in this respect.

With the above-stated objects in view the invention consists in certain novel constructions and combinations of parts, which are recited in the appended claims.

The drawings which accompany and form part of this specification illustrate an embodiment of the invention.

Figure 1 shows a side elevation of a lathe equipped with my improvements. Fig. 2 shows a section on line 2 2 of Fig. 1, looking toward the right. Fig. 3 shows a section on line 3 3 of Fig. 1, looking toward the right. Fig. 4 shows a section on line 4 4 of Fig. 1. Fig. 5 represents a top plan view showing the broad-tool attachment partly in section. Fig. 6 shows a top plan view, on an enlarged scale, of the turret attachment.

The broad-tool attachment as applied to a lathe of the type shown in my prior patent above referred to is of the following-described construction: A main body or frame piece *a*, in the form of a hollow casting, embraces the automatic chuck of the lathe, as shown more clearly in Fig. 5, and is securely bolted to the

head-block *z* of the lathe, the latter being specially prepared for it. The frame-piece or standard *a* rises somewhat above the level of any part of the turret and constitutes a support for one end of a rod or bar *b*, extending longitudinally of the lathe and above the turret, beyond which is located a standard *b'* to support one end of said rod. It will be seen that this rod or bar does not interfere in any way with the operations of the turret or its appurtenances. At a point a short distance from the standard *a* the rod or bar *b* supports a hanger *c*, which is rigidly affixed to it and is formed in its depending portion with holes receiving the ends of short shafts *d*, whose opposite ends are supported and fastened in the standard *a*. Journaled upon these shafts are a pair of frames *e* and *e'*, which constitute tool-holders and are designed to be swung upon the shafts into and out of operative position. Said frames are here shown as holding broad circular tools *f*, designed to turn bicycle-hubs; but of course various other forms of tools can be employed, according to the work in hand, and, if necessary, the holders can be modified to accommodate them. The tools are arranged to operate simultaneously on opposite sides of the work, and the holder or frames *e* and *e'* are moved toward each other by cams *e²* *e³*, respectively, said cams bearing against the rear sides of the frames, which are formed with shoulders or surfaces suitable for the purpose, as shown in Fig. 2. It will be observed that these cams are cut away sufficiently to permit the tool-holders to be swung upwardly to or slightly beyond the horizontal when not in use. For this purpose one of the holders has a handle *g*, and intermeshing gears *h* *h'*, carried by the holders, transmit the swinging motion from one to the other.

The cam *e²* is affixed on a shaft *e⁵*, journaled in the standard *a* and carrying a worm-wheel *e⁶*, which is engaged by a worm *e⁷*, formed on a quill or sleeve *e⁸*, carrying a hand-wheel *e⁹*. A shaft *e¹⁰* extends through said sleeve and constitutes a support for it, said shaft being journaled in bearings on the standard *a* and carrying at its outer end an operating hand-wheel *e¹¹* and at its opposite end on the other side of the standard *a* a worm *e¹²*, which meshes into a worm-wheel *e¹³*, affixed on the

shaft e^{14} , which carries the cam e^8 . A set-screw e^{15} , entered through a boss on the sleeve e^8 over a slot in said sleeve, provides means for locking the sleeve and shaft together, so
 5 that both tool-holders may be simultaneously operated by the turning of one of the wheels e^9 or e^{11} . When the set-screw is withdrawn, the said hand-wheels can be independently turned to separately move the tool-holders.

10 Of course the cams could be worked by power through suitable connections, and it is within the province of my invention to resort to such an expedient when desirable.

Passing now to the improved turret attachment, it is first to be stated that this feature
 15 of my invention has been designed particularly to displace the lever shown in my former patent for feeding the tool-slide on the turret.

Referring to Fig. 6, the letter i designates
 20 the laterally-movable tool-slide, which is formed in its rear edge with a rack, as usual, which is engaged by a pinion j on a spindle j' . In the arrangement shown in my former patent a lever is attached to this spindle and is
 25 manipulated by the operator. In the present case a large gear-wheel j^2 is affixed on the upper end of the said spindle, and a loose or idle gear j^3 meshes with said large gear and also with a pinion j^4 , formed on or affixed to
 30 the stem of a handle pivotally mounted with its center of rotation coincident with that of the turret. This handle may be composed of a central boss j^5 , as shown, with radiating arms j^6 , giving it the form of a pilot-wheel, or
 35 it may be an ordinary hand-wheel, such as e^9 , Fig. 3.

The purpose of the above-described means for operating the tool-slide is partly to obtain
 40 a greater leverage and partly to locate the handle centrally over the turret, so as to overcome an objection to the former arrangement in that the quick operation of the turret sends the lever flying loose to strike the operator or interfere with other mechanism of the lathe.

45 It is to be understood that the invention herein disclosed is capable of embodiment in different forms than shown, and is not therefore limited in this respect.

I claim—

50 1. An attachment for turret-lathes, comprising standards on the lathe-bed on opposite sides of the turret and at the ends of the turret-slideways and projecting beyond the plane of the top of the turret; a stationary
 55 rod or bar supported by said standards at the outer parts thereof and extending over the turret; and tool-holders swung from said rod or bar.

2. An attachment for turret-lathes, the same
 60 comprising a supporting-frame constructed and arranged to be mounted on the lathe without forming an obstruction to the turret or its adjuncts; one or more tool-holders pivotally supported at the outer part of said frame so
 65 as to swing laterally; and means for adjusting said holders on their pivots without per-

manent engagement therewith but with provisions for permitting the said holders to be swung free of said adjusting means to leave an unobstructed space for the turret and its
 70 adjuncts, substantially as described.

3. An attachment for turret-lathes, comprising a frame constructed to embrace the lathe-chuck; one or more tool-holders located
 75 outwardly beyond said frame to overhang the lathe-bed and pivotally supported from said frame; and means for controlling the position of said tool-holders with provisions for permitting the same to be swung out of the way to leave an unobstructed space for the
 80 turret and its adjuncts.

4. An attachment for turret-lathes, comprising a frame constructed to embrace the lathe-chuck; one or more tool-holders located
 85 outwardly beyond said frame to overhang the lathe-bed and pivotally supported from the said frame; and means for adjusting the holders on their pivots with provisions for permitting the said holders to be swung out of the way, said means being arranged in the
 90 frame between the lathe-chuck and the lathe-bed.

5. An attachment for turret-lathes, comprising standards mounted on the lathe-bed on opposite sides of the turret and at the ends
 95 of the turret-slideways and projecting beyond the plane of the top of the turret; a fixed rod or bar supported by said standards and extending over the turret; a hanger fastened to and supported by said rod or bar; shafts supported
 100 between said hanger and one of the standards; and swinging tool-holders on said shafts.

6. An attachment for turret-lathes, the same comprising a supporting-frame constructed
 105 and arranged to be mounted on the lathe without forming an obstruction to the turret or its adjuncts; one or more tool-holders pivotally supported at the outer part of said frame so as to swing laterally toward and from the
 110 work; and one or more cams engaging the holder or holders on the outer side to advance the same toward the work, with provisions for permitting the holder or holders to be swung free to leave an unobstructed space for the
 115 turret and its adjuncts, substantially as described.

7. An attachment for lathes, the same comprising a suitable framework or support, a pair of tool-holders pivotally supported by
 120 the same, cams supported behind said tool-holders and bearing against them, and means for operating said cams with provision for simultaneously or independently moving them.

8. An attachment for lathes, the same comprising a suitable framework or support, a pair of tool-holders pivotally supported there-
 125 by, cams supported behind said tool-holders and bearing against them, worm-wheels associated with said cams, a shaft carrying a worm in engagement with one of said wheels, a
 130 sleeve or quill on said shaft and having a worm

engaging the other of said wheels, and means for connecting together and disconnecting said shaft and sleeve.

9. An attachment for lathes, the same comprising a body or frame piece constructed to embrace the lathe-chuck, a rod or bar supported at one end by the said frame-piece, a support for the opposite end of said rod or bar, a hanger on said rod or bar, shafts supported between said frame-piece and said hanger, tool-holders pivotally mounted on said shafts, and means for controlling said tool-holders.

10. In a turret-lathe, the combination with the laterally-movable tool-slide, having a

rack, of a spindle carrying a pinion in mesh with said rack and a larger gear-wheel, a handle pivoted over the middle of the turret and carrying a pinion, and a loose intermediate gear connecting said pinion with the large gear on the before-mentioned spindle.

In testimony whereof I have signed my name to this specification, in the presence of two subscribing witnesses, this 27th day of May, A. D. 1896.

JAMES HARTNESS.

Witnesses:

E. R. FELLOWS,
E. E. WOOD.